



GAI-TRONICS®
A HUBBELL COMPANY

Model 780-002, 785-002, 7805-002, and 7855-002 24 V DC Explosion-proof Handset Stations

Confidentiality Notice

This manual is provided solely as an operational, installation, and maintenance guide and contains sensitive business and technical information that is confidential and proprietary to GAI-Tronics. GAI-Tronics retains all intellectual property and other rights in or to the information contained herein, and such information may only be used in connection with the operation of your GAI-Tronics product or system. This manual may not be disclosed in any form, in whole or in part, directly or indirectly, to any third party.

General Information

GAI-Tronics hazardous area Page/Party® 24 V dc handset/speaker stations are designed to provide safe and clear communications even in high-noise areas. These models are NRTL certified for use in the US and Canada for the following areas: Class I, Div. 1, Groups C and D; Class II, Div. 1, Groups E, F, and G; and Class III, Div. 1.

Each of these models include a front-panel push button for paging, a durable 6-foot PVC coil cord, a noise-canceling microphone for reduced transmission of background noise, and sidetone circuitry to reduce amplification of the user's voice into their earpiece. An electrical safety barrier mounted inside the housing creates an intrinsically-safe handset. Multi-party stations include a durable rotary switch for party line selection. The following models are covered by this instruction manual:



Model	Description
780-002	Explosion-proof Handset Station, indoor, 24 V dc, single party
7805-002	Explosion-proof Handset Station, indoor, 24 V dc, multi-party
785-002	Explosion-proof Handset Station, weatherproof, 24 V dc, single party
7855-002	Explosion-proof Handset Station, weatherproof, 24 V dc, multi-party

This installation manual provides instructions on both the placement and mounting of the stations. Refer to Pub. 42004-182, which shows the conduit installation and station wiring details necessary to maintain the explosion-proof integrity of the stations.

⚠ WARNING ⚠ **Explosion Hazard – Do not connect or disconnect equipment unless power has been switched off or the area is known to be non-hazardous.**

Installation

Whether installing an entire system or only an add-on station, consult the 24 V dc system layout diagrams at the end of this manual. These figures, used in conjunction with the station installation information and the cable layout guide, should provide all the information necessary to install the Page/Party[®] stations. These figures do not show an explosion-proof station; however, the basic points of the system layout and design still apply.

 **NOTE**  A separate power feed is recommended for Page/Party[®] stations in Div.1 areas. With a separate power feed, the Page/Party[®] stations can be shut off for maintenance without disrupting the power supply to the other equipment in the Div. 1 area.

In 24-volt systems, plan on several branch lines from the dc source with no more than six stations per branch. One branch could span up to 4,000 feet for a single station. The Maximum Cable Distance Table lists the limits. Where two or more stations are listed, the assumption is that they are evenly spaced along the cable.

Each amplifier contains two fuses on the PCBA in the 24 V dc input to protect and isolate the handset and speaker amplifier circuitry in the event of a failure. Power line wiring to each amplifier or group of amplifiers should have a fuse or circuit breaker to protect against wiring failures.

If cable with No. 14 AWG power line conductors is used, a 15-amp fuse or circuit breaker should be installed for each branch line at the point it connects to the battery. Fuse or circuit breaker rating is determined by the size cable used in the branch. Consult the National Electrical Code (NFPA70) or Canadian Standards Association (CSA 22.1) for the maximum allowable capacity of the wire used.

The GAI-Tronics 24 V dc series of Page/Party[®] system equipment is designed to operate from a 24 volt dc rechargeable battery. A battery charger can be connected to the battery to maintain the charge.

 **CAUTION**  **Under NO condition should this equipment be operated from a battery charger without the batteries connected.**

Most chargers have an unloaded output of 35 to 45 volts that can quickly damage the equipment designed for nominal 24 volts. To maintain a proper state of battery charge, the voltage across the batteries will be somewhat greater than 24 volts, but should never exceed 28.8 V dc. Grounding the negative side of the battery system at only one point is recommended and will ensure hum- and noise-free operation.

Enclosure Placement

All GAI-Tronics Page/Party[®] units are wired in parallel. Good system layout design minimizes the cable required for each installation. GAI-Tronics multi-conductor cable, designed especially for this application, is recommended. The number, size, and color-coding of conductors are listed in the accompanying system connection diagrams.

System layout and power cable length are important considerations when installing Page/Party[®] equipment. Consult the Maximum Cable Distance table for typical cable lengths. The cable distance between stations as well as total cable distance must be considered. Cable distance is more strictly regulated in 24 V dc systems because of the amount of resistance these cables encounter—the longer the cable distance, the greater the resistance and IR losses (voltage drop) encountered.

Maximum Cable Distance in Feet*

Number of Units	No. 14 AWG Total / Between	No. 12 AWG Total / Between	No. 10 AWG Total / Between	No. 8 AWG Total / Between
1	977 / 977	1,554 / 1,554	2,471 / 2,471	3,931 / 3,931
2	651 / 325	1,037 / 518	1,648 / 824	2,620 / 1,310
3	489 / 163	777 / 259	1,236 / 412	1,966 / 655
4	391 / 98	622 / 155	988 / 247	1,572 / 393
5	325 / 65	518 / 103	823 / 165	1,310 / 262
6	279 / 46	444 / 74	706 / 117	1,123 / 187
9	196 / 21	311 / 34	494 / 55	786 / 87

*Based on the following assumptions:

- Continuous tone (alarm) signals driving each station’s speaker amp to a maximum of 12 watts.
NOTE: If the station is used for speech (audio) signals **only**, the distances stated above can be multiplied by a factor of 2 because speech signals do not have the energy content that a continuous tone has; therefore, they do not require as much average current and thus less cable IR drop will result.
- GAI-Tronics-supplied cable is used.
- Wire resistance (ohms) is the nominal value for the applicable AWG at 1,000 feet of bare copper, stranded wire @ 20° C (68° F). Wire resistance values used are as follows:
No. 14 AWG = ~2.525 ohms; No. 12 AWG = ~1.588 ohms; No. 10 AWG = ~0.999 ohm; No. 8 AWG = ~0.628 ohm
- DC V at cable run’s feed point (Float charge of connected batteries) = ~26.6 V dc
- DC V at the last unit in cable run = 21 V dc minimum
- Station unit current draw (I) is the same regardless of the unit’s placement along the cable run for ease of calculation. (1.1 amperes when unit is producing a 12-watt sine wave output.)
- Distances reflect a 3% reduction for margin of error.

For conditions other than above, the following formula may be helpful in calculating the approximate maximum distance for a SINGLE station.

For **CONTINUOUS** tone applications with minimum distortion:

$$\frac{V_{\text{FEEDPOINT}} - V_{\text{MINIMUM}}}{(2 \times \text{AWG WIRE RESISTANCE PER FOOT @ } \sim 20^{\circ}\text{C}) \times \text{UNIT I [IN AMPS @12W OUT]}} = \text{APPROXIMATE MAXIMUM DISTANCE IN FEET}$$

For **SPEECH** operation only, multiply the above result by a factor of 2.

Example: What is the approximate maximum distance for a **single** dc station if the voltage feed is 27.5 V dc and a No. 14 AWG wire is used @ 20° C?

Info:

- No. 14 AWG @ 20° C = ~0.002525 ohm per foot × 2 for LOOP R
- V_{FEEDPOINT} = 27.5 V dc

Solution:

$$\begin{aligned} & (27.5 \text{ V} - 21 \text{ V}) / ((2 \times 0.002525 \text{ ohm per foot}) \times 1.1 \text{ amps}) \\ & = 6.5 / 0.005555 \\ & = 1,170 \text{ feet (for CONTINUOUS TONE signal), or up to } \sim 2,340 \text{ feet (factor of 2) for SPEECH signals} \end{aligned}$$

Mounting



To maintain the explosion-proof integrity of these stations, all mounting hardware is located outside the aluminum enclosure. The suggested mounting height for all station enclosures is 54 inches (137 mm) up to the centerline of the enclosure.

Indoor Station: Mount the indoor unit using the two mounting straps on the rear of the enclosure. Refer to Figure 1. Use the standard $\frac{3}{8}$ -inch bolts to secure the enclosure to the mounting surface. Secure the bottom two bolts first, then the top bolts. The mounting strap design allows the station to be removed from its mounting surface by removing only two of the bolts.

Outdoor Station: The outdoor model stations are shipped with a separate weatherproof nonmetallic enclosure with a front door. This enclosure has four 0.44-inch diameter mounting feet in the 4 corners and is suitable for mounting to many types of surfaces. Refer to Figure 2.

Conduit Installation

Refer to Pub. 42004-182, which is shipped with this unit. This publication details how to maintain the explosion-proof integrity of the station.

 **NOTE**  **External conduits in areas with Class I, Group C and D areas must have gas seals not more than 18 inches (457 mm) from the station enclosure. External conduits in Class II and Class III areas must have seals if the conduit system is not dust-tight.**

Wiring

After the station has been mounted, use a $\frac{7}{16}$ -inch wrench to open the front panel of the station to access the Termination PCBA. Refer to Pub. 42004-182 for wiring details.

Feed the wiring through the conduit and into the enclosure. Follow the wire colors carefully—these colors correspond to GAI-Tronics 60029 or 60038 Series cable. The wires must be spade-lugged and connected carefully and completely to the terminal block. An improper termination may result in diminished station performance.

Before closing the station, plug the power interconnect cable from the front of the enclosure into the connector on the power supply card in the rear enclosure.

 **NOTE**  **All the bolts must be installed to maintain the integrity of the explosion-proof construction.**

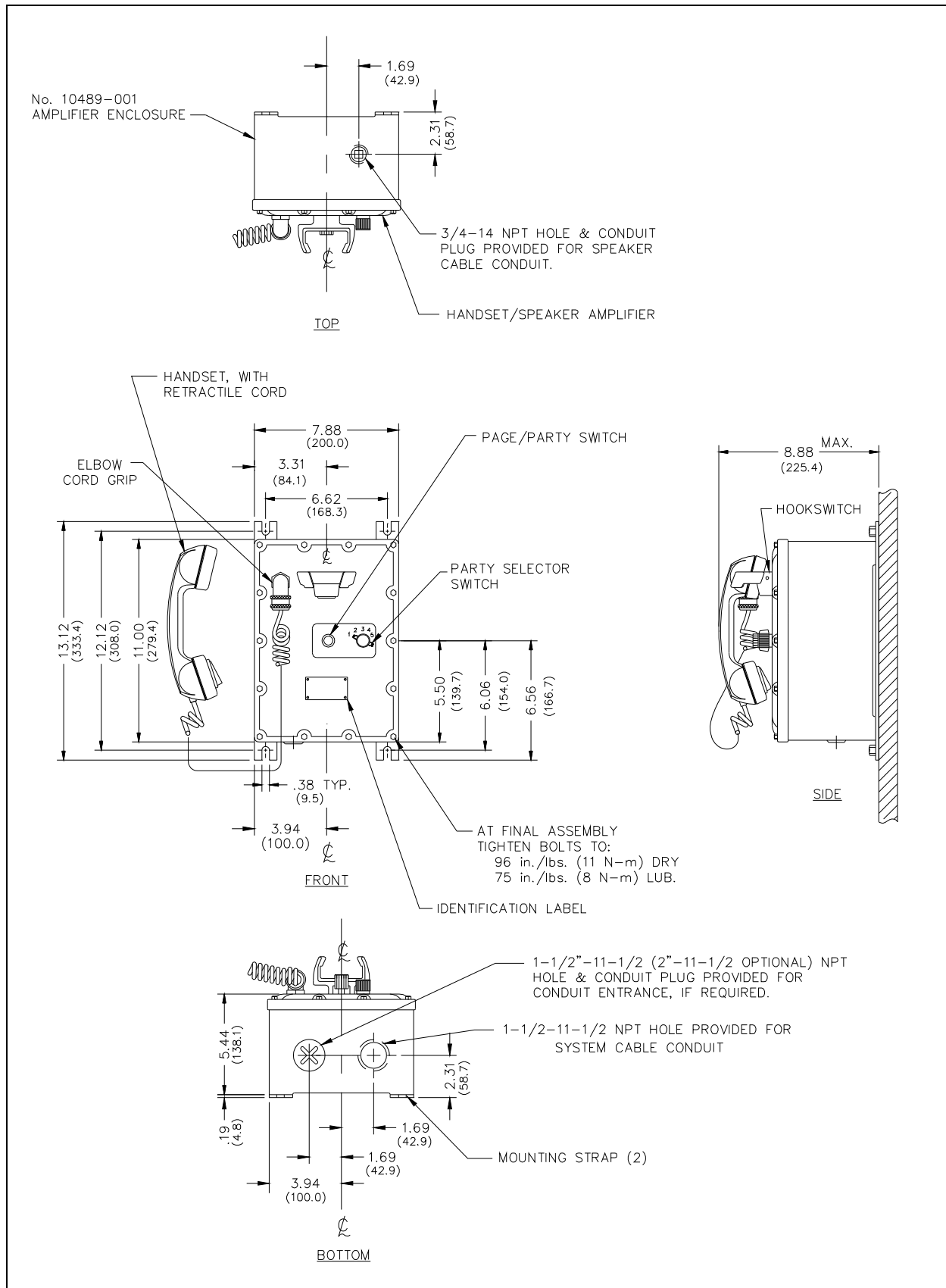

Figure 1. Mounting details for indoor stations (multi-party station shown)

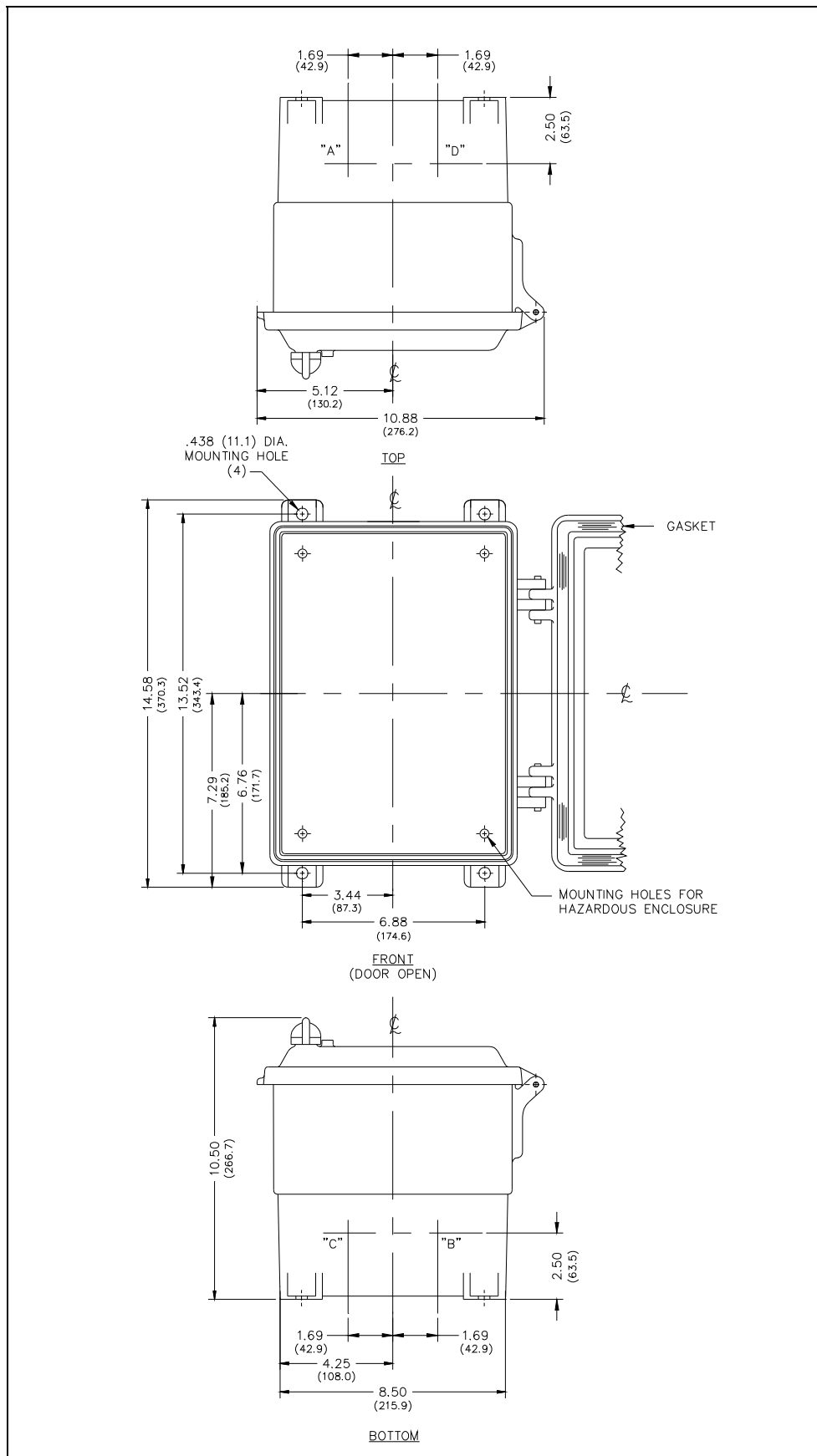

Figure 2. Mounting details for outdoor stations

Speaker Muting Information

These stations are equipped with a muting feature that is used if the station is located near other handset/speaker stations. This feature prevents acoustic feedback between stations during paging by muting the station's associated speaker. These stations are shipped from the factory with the mute feature enabled.

To disable the muting feature, remove jumper W6 located on the 10489-002 Termination PCBA.. The chart below describes how the muting function operates when specific combinations of wire jumpers W3, W4, W5, and W6 are installed on the Termination PCBA.

W3	W4	W5	W6	Description of Operation
O	X	X	X	AUX/PAGE inputs to the amplifier are muted during station page (as shipped from GAI-Tronics—see the note).
O	X	X	O	AUX/PAGE inputs to the amplifier are not muted during a station page.
O	X	O	X	PAGE input is muted only during a station page.
X	X	O	X	PAGE input is muted during a station page or by contact closure between the Mute A and B inputs.
X	O	X	X	PAGE/AUX inputs are muted during a station page or by contact closure between the Mute A and B inputs.
X	O	O	O	PAGE/AUX inputs are not muted. Isolated normally open relay contact output between the Mute A and B terminals is closed during station pages.

X = Installed

O = Not Installed.

Mutual Muting

NOTE: Jumpers W4, W5, and W6 must be installed.

Stations that are located closely together may require *mutual muting* of the page amplifiers. To accomplish mutual muting between stations, connect the orange (spare) wire in the GAI-Tronics station cable to TB2-A on each of the Div. 1 stations that require muting. All the mutually muted stations are muted when any connected station is paging.

Mutual muting can be accomplished between the Div. 1 stations and Div. 2 enclosures using most GAI-Tronics 600 or 700 Series enclosures by connecting the orange (spare) wire between TB2-11(A) on the Div. 1 station and TB1-7 on the Div. 2 enclosure:

Div. 1 Stations (TB2-A)	Div. 2 Enclosures (TB1-7)		
670-002	702-002	733-002	703-002
780-002	732-102	7335-002	
7805-002	7325-102	758-002	

Consult GAI-Tronics for any enclosures not listed.

NOTE: The auxiliary speaker amplifier input is a balanced 10-kilohm audio input.

Operation

GAI-Tronics offers two types of Page/Party[®] systems: Single party with one page line and one party line, and multi-party with one page line and five party lines allowing up to five simultaneous two-way conversations.

For *single party* systems, complete the following steps to make a page announcement:

1. Lift the handset from the cradle.
2. Depress and hold the handset pressbar.
3. Speak directly into the microphone to broadcast your announcement over the loudspeakers.
4. Release the handset pressbar, and if requested, wait for a response.

The paged individual(s) responds by picking up a station handset.

For *multi-party* systems, complete the following steps to make a page announcement:

1. Lift the handset from the cradle. If party line conversation is desired, rotate the selector switch to an unoccupied party line.
2. Depress and hold the handset pressbar.
3. Speak directly into the microphone to broadcast your announcement over the loudspeakers.
4. Release the handset pressbar, and if requested, wait for a response.

The paged individual(s) responds by picking up a station handset and turning the selector switch to the requested party line.

With either type of system, the full duplex party line communication is not broadcast over the system speakers. Other individuals can also pick up and join the conversation at any time. Always return the handset to the cradle following a page or a party line conversation.

Maintenance

The following adjustments are accessible through the rear amplifier chassis using a small screwdriver. The handset/speaker amplifier section must be completely removed from the enclosure to access these controls. A silk-screen on the rear of the amplifier indicates the different controls.

- *Microphone Gain*: adjusts the gain level from the microphone signal to the page or party lines
- *Receiver Sidetone*: adjusts the amount of signal transmitted from the microphone to the receiver. To properly adjust the sidetone, blow into the receiver while adjusting the sidetone level. The sidetone is correctly set when the person blowing into the receiver can barely hear themselves.
- *Receiver Volume*: adjusts the gain level from a party line to the receiver
- *Speaker Volume*: adjusts the volume level of the speaker (if any) associated with this station

Troubleshooting

The following table lists some hints to aid technicians in troubleshooting.

Problem	Solution
Outgoing conversation level requires adjustment.	Adjust the microphone gain at the amplifier.
Incoming conversation level requires adjustment.	Adjust the receiver volume control at the amplifier.
Sidetone (how the operator hears himself) requires adjustment.	<ol style="list-style-type: none"> 1. Adjust the receiver sidetone at the amplifier. 2. Check that the system cable connections to the resistors in the line balance assembly are properly terminated.
Feedback occurs only during page.	Ensure the muting feature is enabled. See the Mutual Muting section of this manual for details.
Crosstalk occurs.	One or more system cable pairs may be improperly terminated. Visually inspect the system cable connections for accidental crossing of the cable pairs or grounds.

Specifications

Power input 21–29 V dc; 1.2 A (optional negative ground or floating)

Dimensions:

Indoor stations 13.1 H × 7.9 W × 5.6 D (8.9 including handset) inches; (332 × 200 × 143 mm)

Outdoor stations 14.6 H × 10.9 W × 10.5 D inches; (371 × 276 × 226 mm)

Temperature range –22° F to +158° F (–30° C to +70° C)

Shipping weight Indoor: 27 lbs. (12.2 kg); outdoor: 35 lbs. (15.9 kg)

Handset

Material/finish Gray ABS

Microphone 10 ohms, noise-canceling, dynamic

Receiver 150 ohms, dynamic

Cable Retractable with sealed elbow, 6-foot extended length

Handset Amplifier

Output 1.5 V nominal into 33-ohm load

Gain 55 dB, adjustable

Frequency response 250–4000 Hz, +0/–3 dB ref @ 1 kHz (1.5 V_{RMS}) output

Distortion 1.5% maximum THD @ 1 kHz

Preset adjustments Microphone gain, sidetone adjustment, receiver volume

Speaker Amplifier

Output @ 25 V dc: 12 watts minimum into 8- or 16-ohm load

Voltage gain 20 dB minimum, adjustable

Frequency response 250–4,000 Hz; +0/–3 dB ref @ 1 kHz

Distortion 1% maximum THD @ 1 kHz/12 watts

Input impedance 50,000 ohms minimum @ 1 kHz

Controls, preset adjustments Speaker volume

Explosion-proof Enclosure

Material/finish No. 359.2 Aluminum alloy

Mounting Wall or column, four 3/8-inch slotted mounting feet

Connections Internal screw-type barrier terminal blocks

Conduit entry Standard hole size top: 3/4 NPT; standard size hole bottom 1 1/2-inch NPT

Weatherproof Enclosure

Material/finish Glass-reinforced polyester

Mounting Wall or column

Environmental rating NEMA 4X

Approvals

NRTL certified for use in US and Canada Class I, Div. 1, Groups C and D
 Class II, Div. 1, Groups E, F, and G
 Class III, Div. 1

REPLACEMENT PARTS

Part No.	Description	780-002	785-002	7805-002	7855-002
10108-007	Handset Assembly, 6-foot coil cord	■	■	■	■
10108-008	Handset Assembly, 15-foot coil cord	■	■	■	■
10108-009	Handset Assembly, 25-foot coil cord	■	■	■	■
10444-003	Weatherproof Enclosure		■		■
12251-001	Spring Door Kit		■		■
12502-101	Receiver Kit	■	■	■	■
12504-004	Replacement Door Handle		■		■
12505-003	Replacement Door Kit		■		■
12511-001	Dynamic Transmitter and Cap	■	■	■	■
12519-001	Replacement Hook and Hinge Kit	■	■	■	■
12604-004	Fuse, 2-amp, (10 pack)	■	■	■	■
12604-005	Fuse, 3/10-amp, (10 pack)	■	■	■	■
13204-002	Receiver Cap	■	■	■	■
24201-009	Page Switch Knob	■	■	■	■
24201-010	Party-line Switch Knob			■	■
12542-001	Replacement Front Cover Bolts	■	■	■	■
61514-005	Harness Assembly	■	■	■	■
69012-002	PCBA Handset Safety Barrier	■	■	■	■
69488-103	PCBA Handset /Speaker Amplifier	■	■		
69488-104	PCBA Handset/Speaker Amplifier			■	■
69489-002	PCBA Amplifier (Enclosure)	■	■	■	■
12571-001	Maintenance Cover Kit	■	■	■	■

TYPICAL MULTI-PARTY SYSTEM CONNECTION DIAGRAM

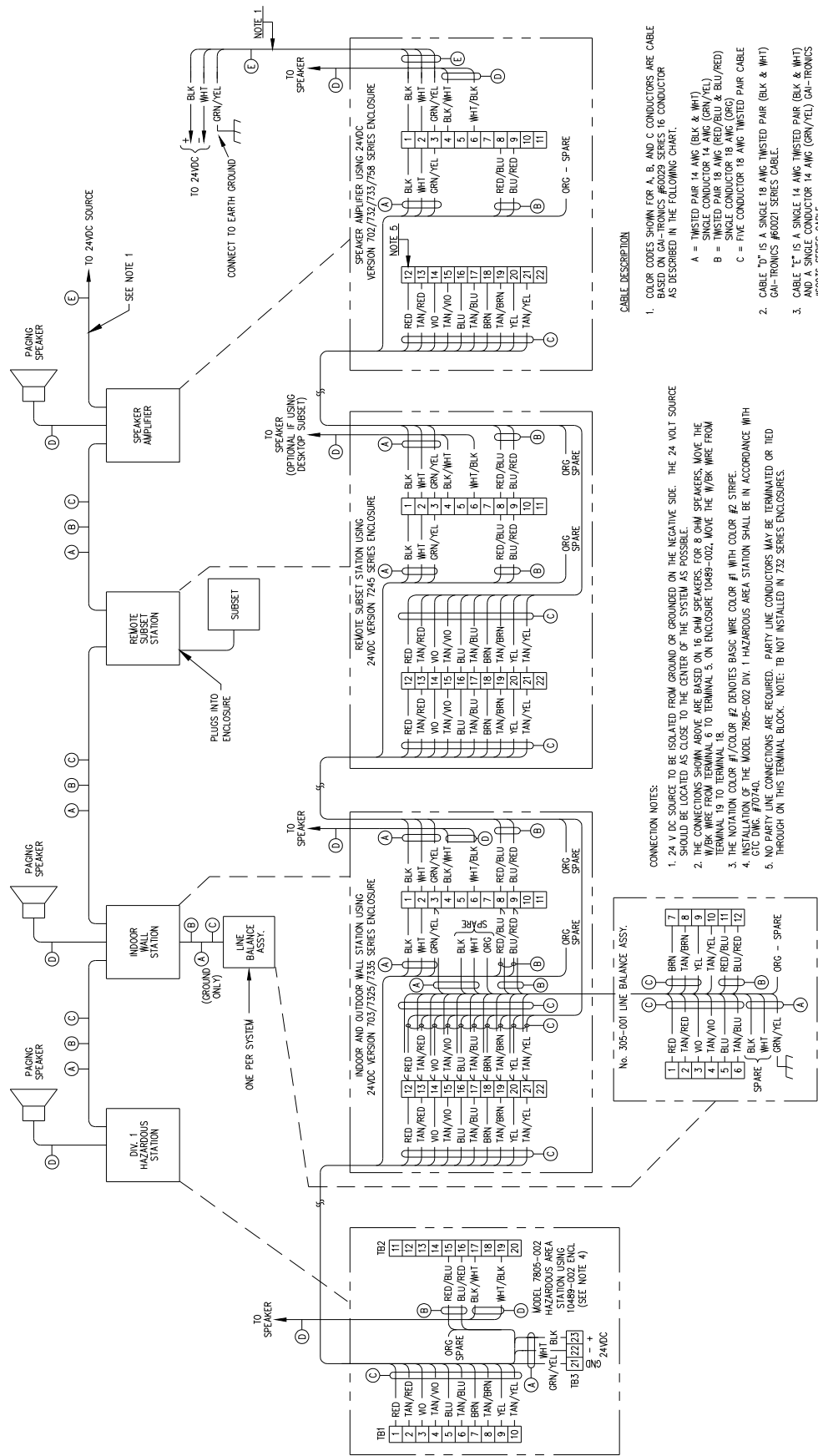

CABLE DESCRIPTION

- COLOR CODES SHOWN FOR A, B, AND C CONDUCTORS ARE CABLE BASED ON GAI-TRONICS #60029 SERIES 16 CONDUCTOR AS DESCRIBED IN THE FOLLOWING CHART.
 - A = TWISTED PAIR 14 AWG (BLK & WHT)
 - B = TWISTED PAIR 18 AWG (RED/BLU & BLU/RED)
 - C = FIVE CONDUCTOR 18 AWG TWISTED PAIR CABLE
- CABLE "D" IS A SINGLE 18 AWG TWISTED PAIR (BLK & WHT) GAI-TRONICS #60021 SERIES CABLE.
- CABLE "E" IS A SINGLE 14 AWG TWISTED PAIR (BLK & WHT) AND A SINGLE CONDUCTOR 14 AWG (GRN/YEL) GAI-TRONICS #60036 SERIES CABLE.

CONNECTION NOTES:

- 24 V DC SOURCE TO BE ISOLATED FROM GROUND OR GROUNDED ON THE NEGATIVE SIDE. THE 24 VOLT SOURCE SHOULD BE LOCATED AS CLOSE TO THE CENTER OF THE SYSTEM AS POSSIBLE.
- WIRE CONNECTIONS ABOVE THE SPEAKERS FOR 8 OHM SPEAKERS: MOVE THE WIRE FROM TERMINAL 19 TO TERMINAL 18. ON ENCLOSURE 10489-002, MOVE THE WIRE FROM TERMINAL 19 TO TERMINAL 18.
- THE NOTATION COLOR #1/COLOR #2 DENOTES BASIC WIRE COLOR #1 WITH COLOR #2 STRIPE.
- INSTALLATION OF THE MODEL 7805-002 DIV. 1 HAZARDOUS AREA STATION SHALL BE IN ACCORDANCE WITH CTC DING #70740.
- NO PARTY LINE CONNECTIONS ARE REQUIRED. PARTY LINE CONDUCTORS MAY BE TERMINATED OR TIED THROUGH ON THIS TERMINAL BLOCK. NOTE: 1B NOT INSTALLED IN 732 SERIES ENCLOSURES.

Warranty

Equipment. GAI-Tronics warrants for a period of one (1) year from the date of shipment, that any GAI-Tronics equipment supplied hereunder shall be free of defects in material and workmanship, shall comply with the then-current product specifications and product literature, and if applicable, shall be fit for the purpose specified in the agreed-upon quotation or proposal document. If (a) Seller's goods prove to be defective in workmanship and/or material under normal and proper usage, or unfit for the purpose specified and agreed upon, and (b) Buyer's claim is made within the warranty period set forth above, Buyer may return such goods to GAI-Tronics' nearest depot repair facility, freight prepaid, at which time they will be repaired or replaced, at Seller's option, without charge to Buyer. Repair or replacement shall be Buyer's sole and exclusive remedy. The warranty period on any repaired or replacement equipment shall be the greater of the ninety (90) day repair warranty or one (1) year from the date the original equipment was shipped. In no event shall GAI-Tronics warranty obligations with respect to equipment exceed 100% of the total cost of the equipment supplied hereunder. Buyer may also be entitled to the manufacturer's warranty on any third-party goods supplied by GAI-Tronics hereunder. The applicability of any such third-party warranty will be determined by GAI-Tronics.

Services. Any services GAI-Tronics provides hereunder, whether directly or through subcontractors, shall be performed in accordance with the standard of care with which such services are normally provided in the industry. If the services fail to meet the applicable industry standard, GAI-Tronics will re-perform such services at no cost to buyer to correct said deficiency to Company's satisfaction provided any and all issues are identified prior to the demobilization of the Contractor's personnel from the work site. Re-performance of services shall be Buyer's sole and exclusive remedy, and in no event shall GAI-Tronics warranty obligations with respect to services exceed 100% of the total cost of the services provided hereunder.

Warranty Periods. Every claim by Buyer alleging a defect in the goods and/or services provided hereunder shall be deemed waived unless such claim is made in writing within the applicable warranty periods as set forth above. Provided, however, that if the defect complained of is latent and not discoverable within the above warranty periods, every claim arising on account of such latent defect shall be deemed waived unless it is made in writing within a reasonable time after such latent defect is or should have been discovered by Buyer.

Limitations / Exclusions. The warranties herein shall not apply to, and GAI-Tronics shall not be responsible for, any damage to the goods or failure of the services supplied hereunder, to the extent caused by Buyer's neglect, failure to follow operational and maintenance procedures provided with the equipment, or the use of technicians not specifically authorized by GAI-Tronics to maintain or service the equipment. **THE WARRANTIES AND REMEDIES CONTAINED HEREIN ARE IN LIEU OF AND EXCLUDE ALL OTHER WARRANTIES AND REMEDIES, WHETHER EXPRESS OR IMPLIED BY OPERATION OF LAW OR OTHERWISE, INCLUDING ANY WARRANTIES OF MERCHANTABILITY OR FITNESS FOR A PARTICULAR PURPOSE.**

Return Policy

If the equipment requires service, contact your Regional Service Center for a return authorization number (RA#). Equipment should be shipped prepaid to GAI-Tronics with a return authorization number and a purchase order number. If the equipment is under warranty, repairs or a replacement will be made in accordance with the warranty policy set forth above. Please include a written explanation of all defects to assist our technicians in their troubleshooting efforts.

Call 800-492-1212 (inside the USA) or 610-777-1374 (outside the USA) for help identifying the Regional Service Center closest to you.